

A Only in CO-FH01/CO-W01

B Only in CO-FH02

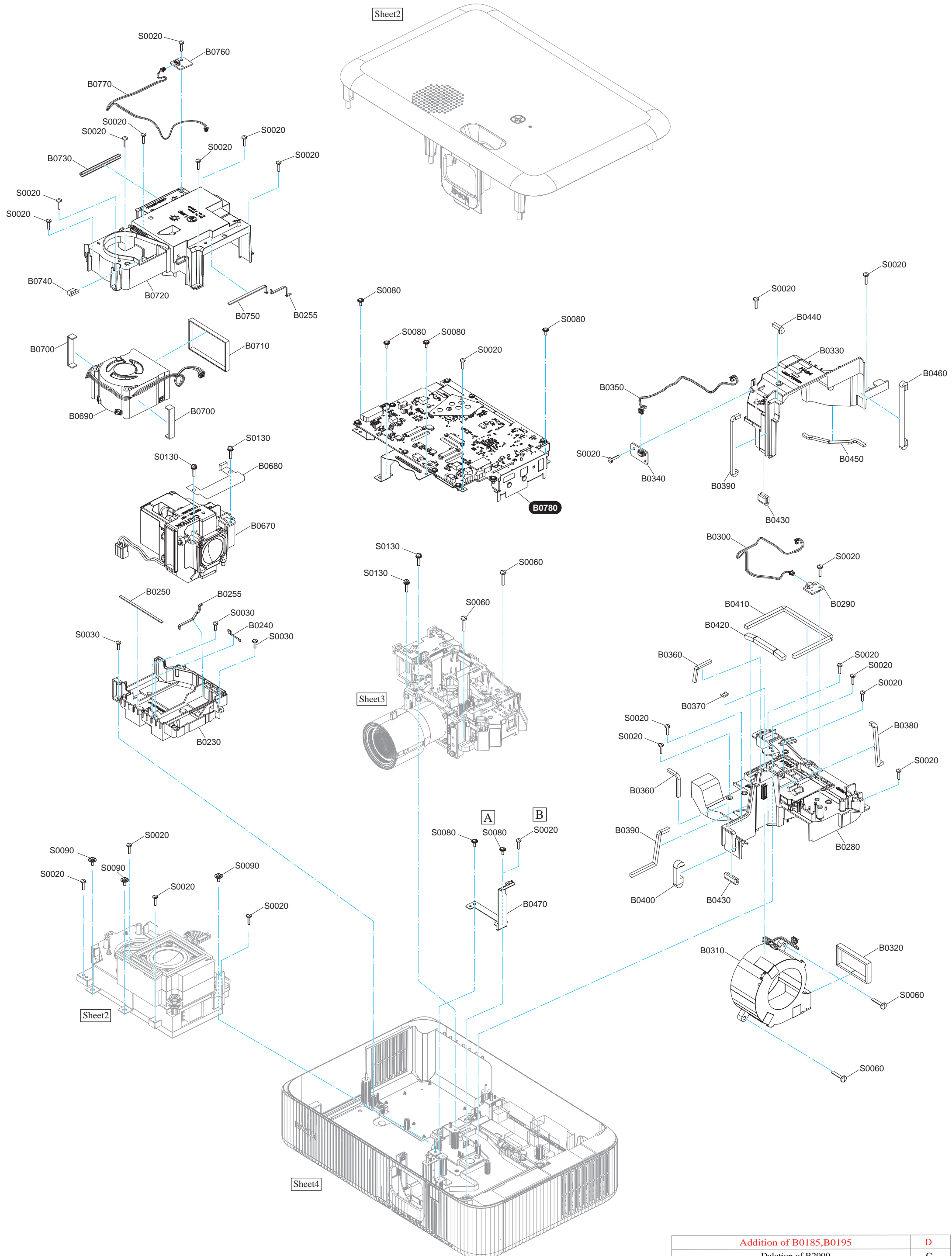

Notes:
 White/Black reversed parts code (written by white text on black circle)
 This parts are different by model and defined multiple parts code (please check SPI for actual parts code)
 By case , some model have no parts though the parts is shown on this diagram.

Addition of B0185,B0195		D
Deletion of B2990		C
Addition of B0255		B
First Release		A
History		Rev.No.
Model Name	CO-FH01/CO-FH02/CO-W01	

A Only in CO-FH01/CO-W01

B Only in CO-FH02

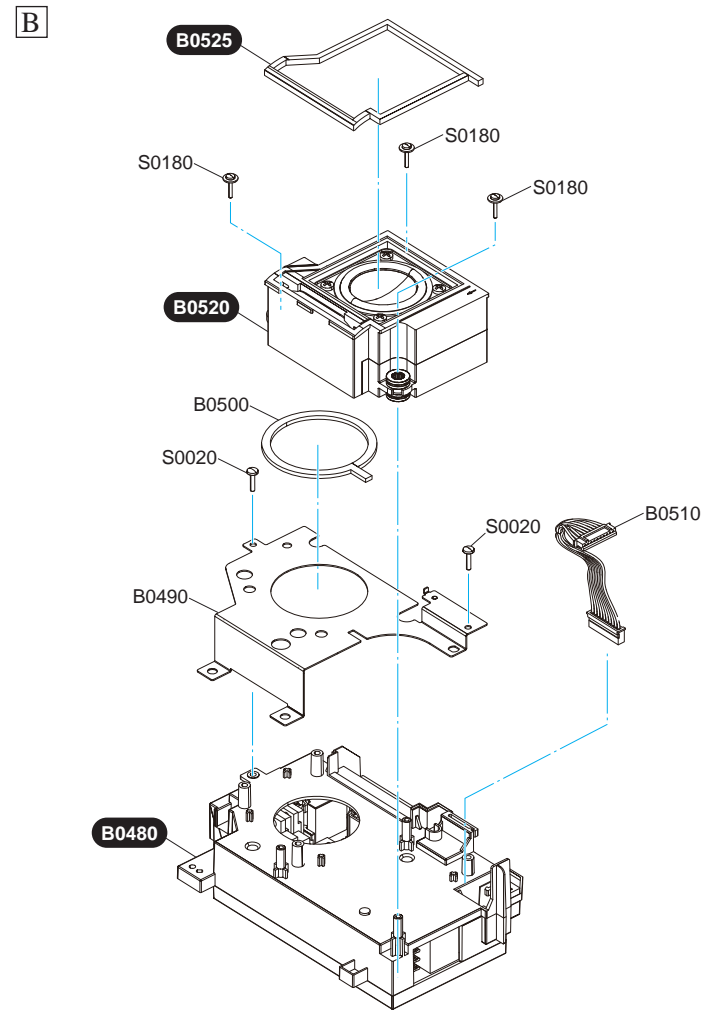
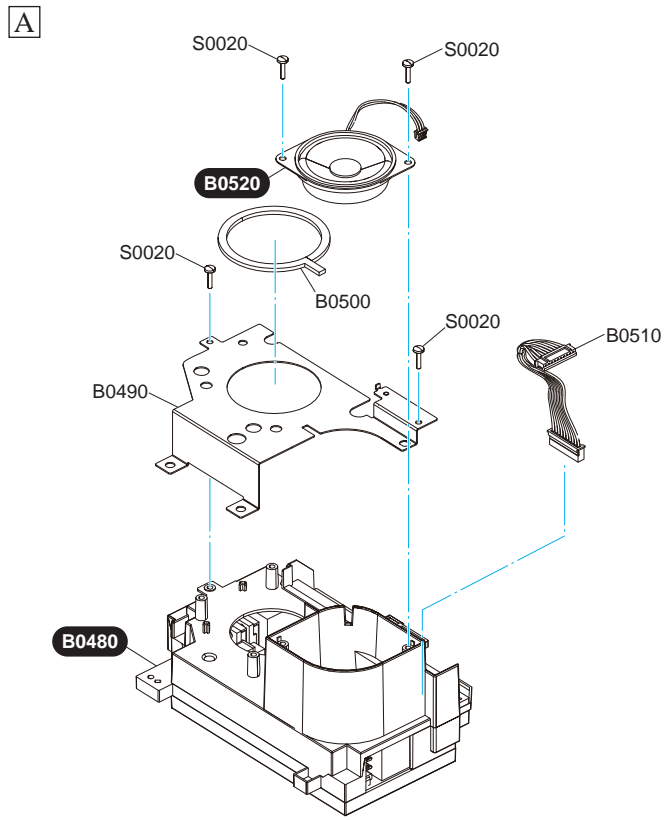
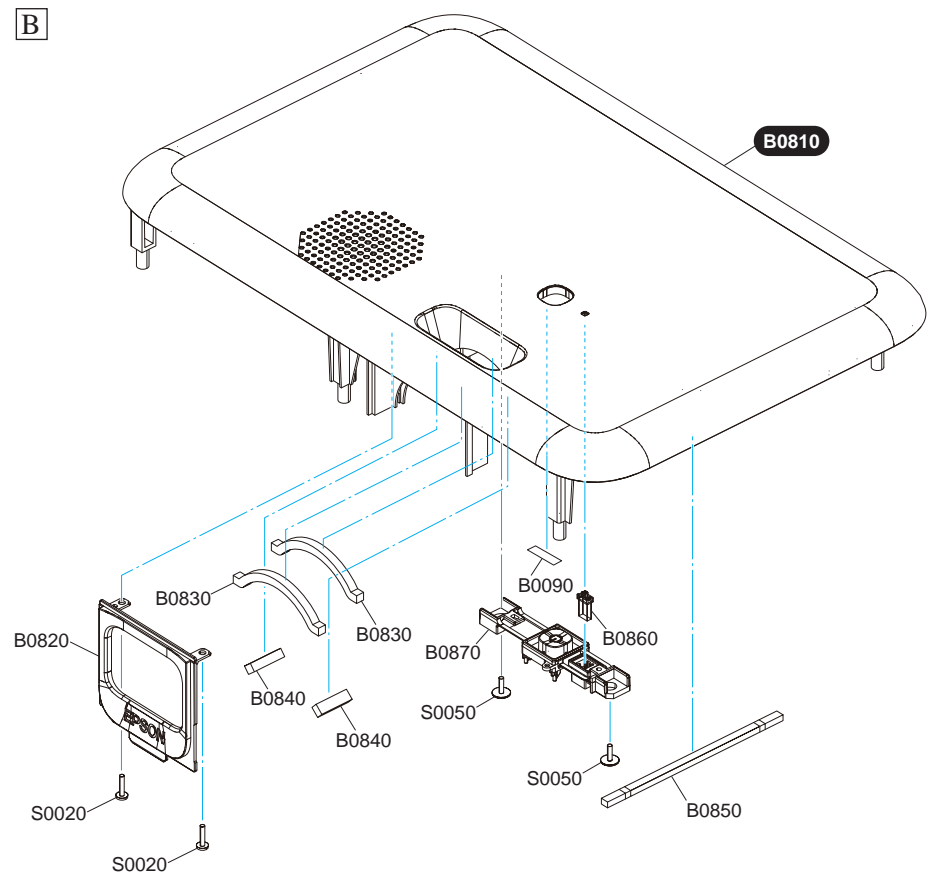
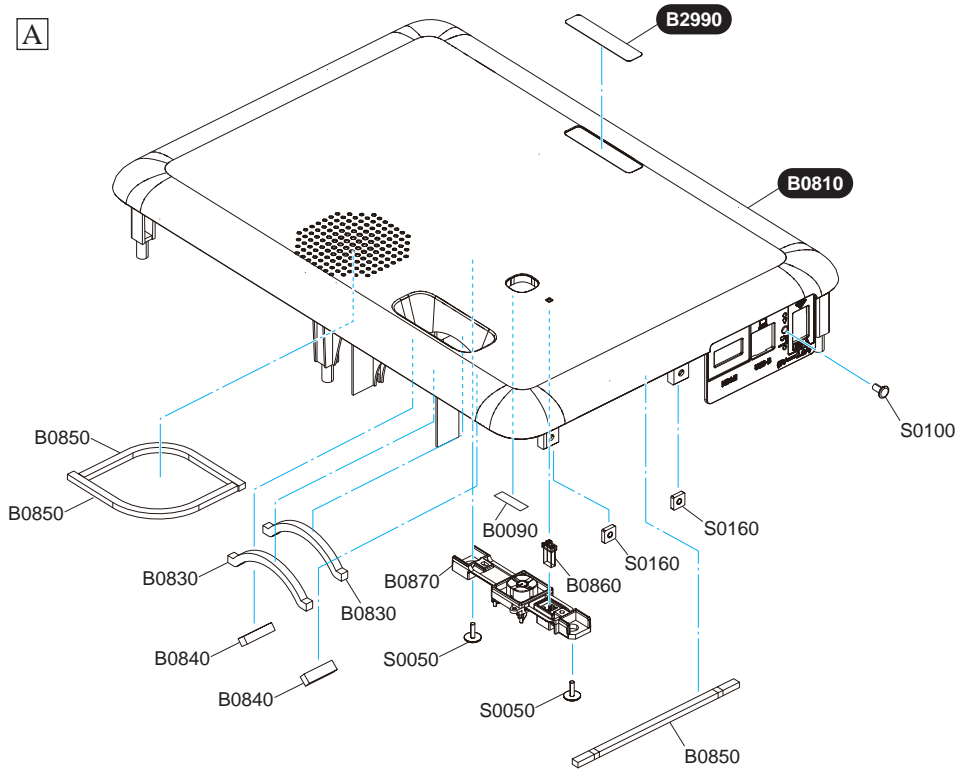

Notes:
 White/Black reversed parts code (written by white text on black circle)
 This parts are different by model and defined multiple parts code (please check SPI for actual parts code)
 By case , some model have no parts though the parts is shown on this diagram.

Addition of B0185,B0195		D
Deletion of B2990		C
Addition of B0255		B
First Release		A
History		Rev.No.
Model Name	CO-FH01/CO-FH02/CO-W01	

B0010

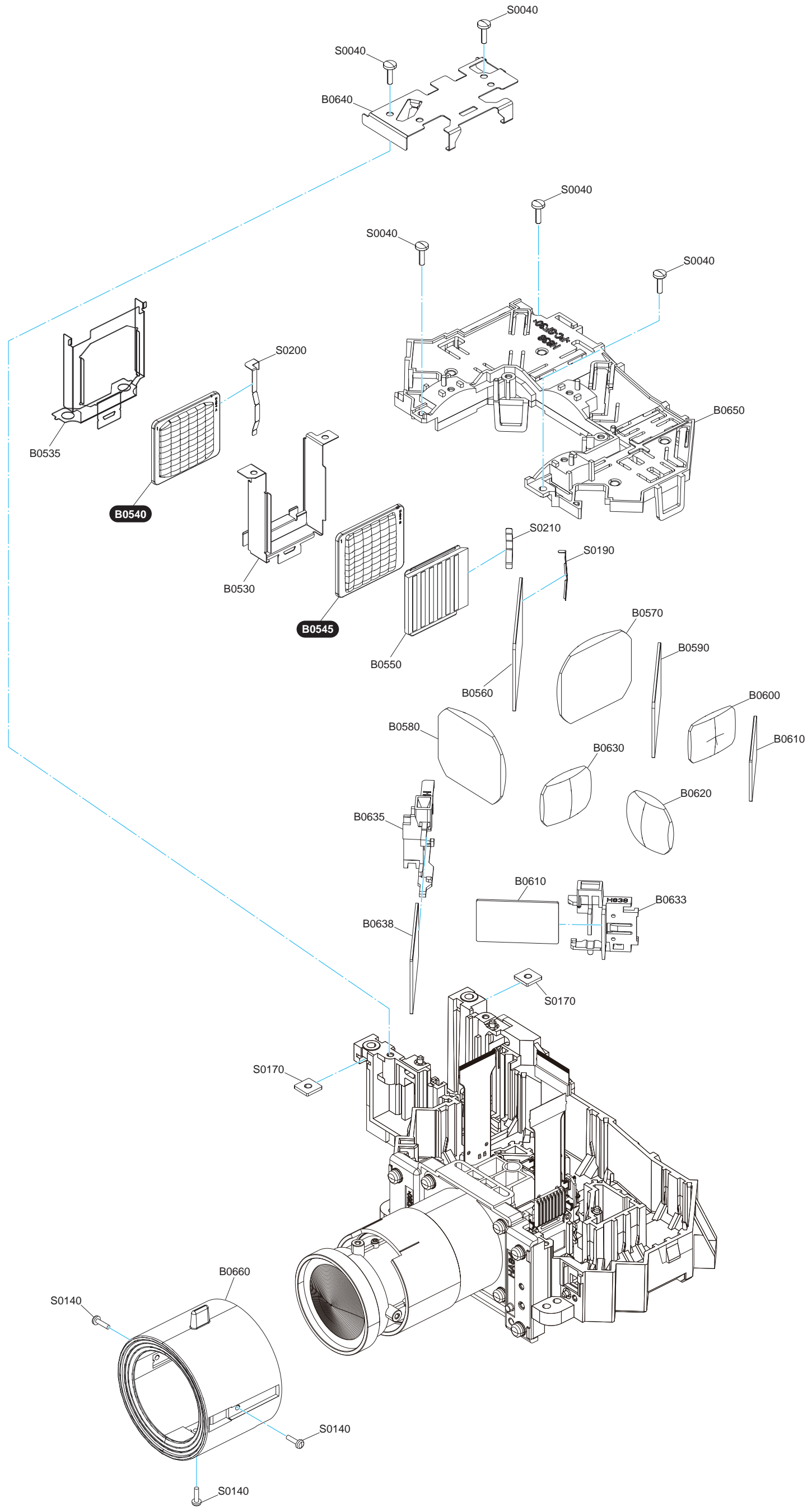

Notes:
 White/Black reversed parts code (written by white text on black circle)
 This parts are different by model and defined multiple parts code (please check SPI for actual parts code)
 By case , some model have no parts though the parts is shown on this diagram.

Addition of B0185,B0195		D
Deletion of B2990		C
Addition of B0255		B
First Release		A
History		Rev.No.
Model Name	CO-FH01/CO-FH02/CO-W01	

A Only in CO-FH01/CO-W01

B Only in CO-FH02

A

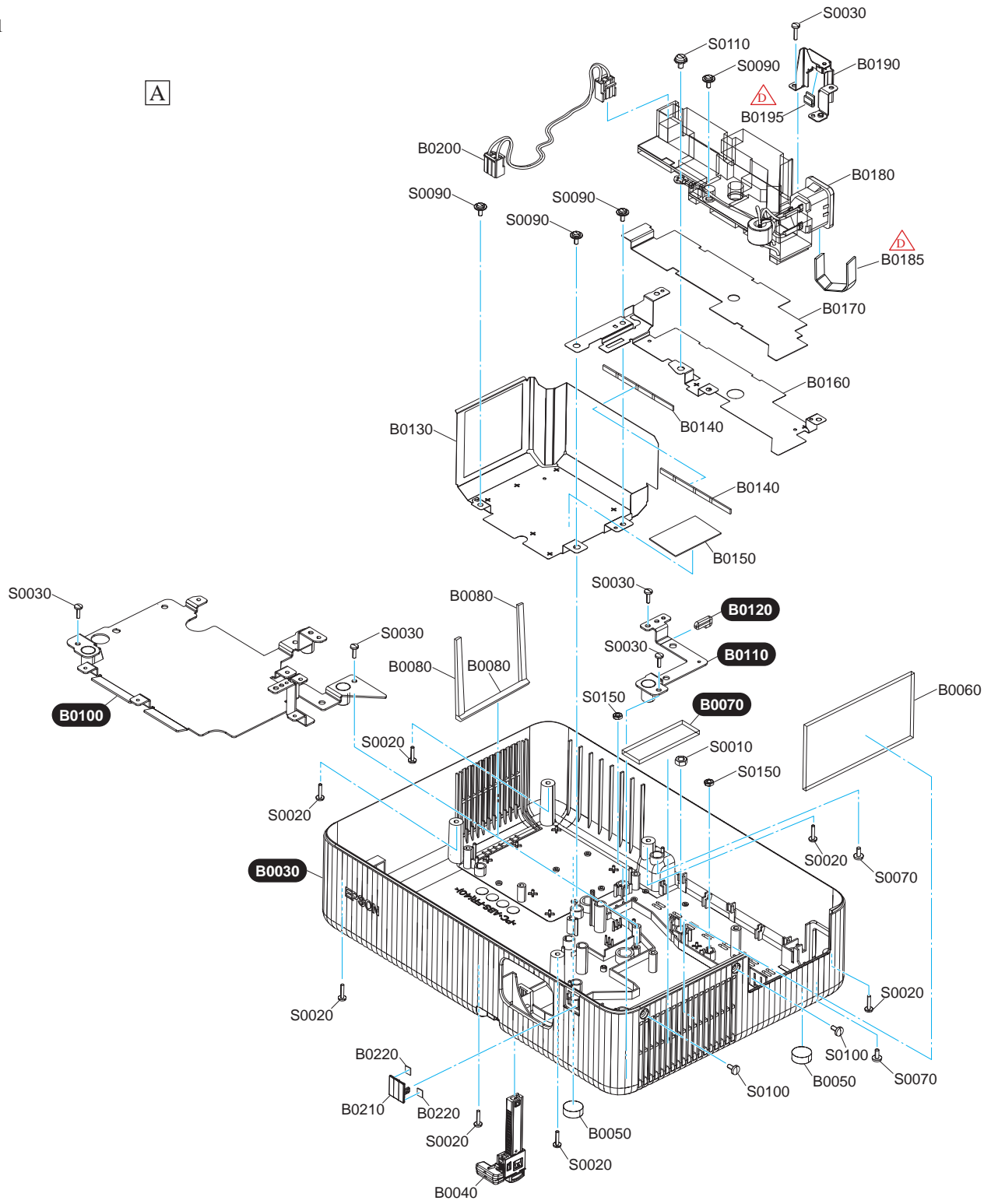

B

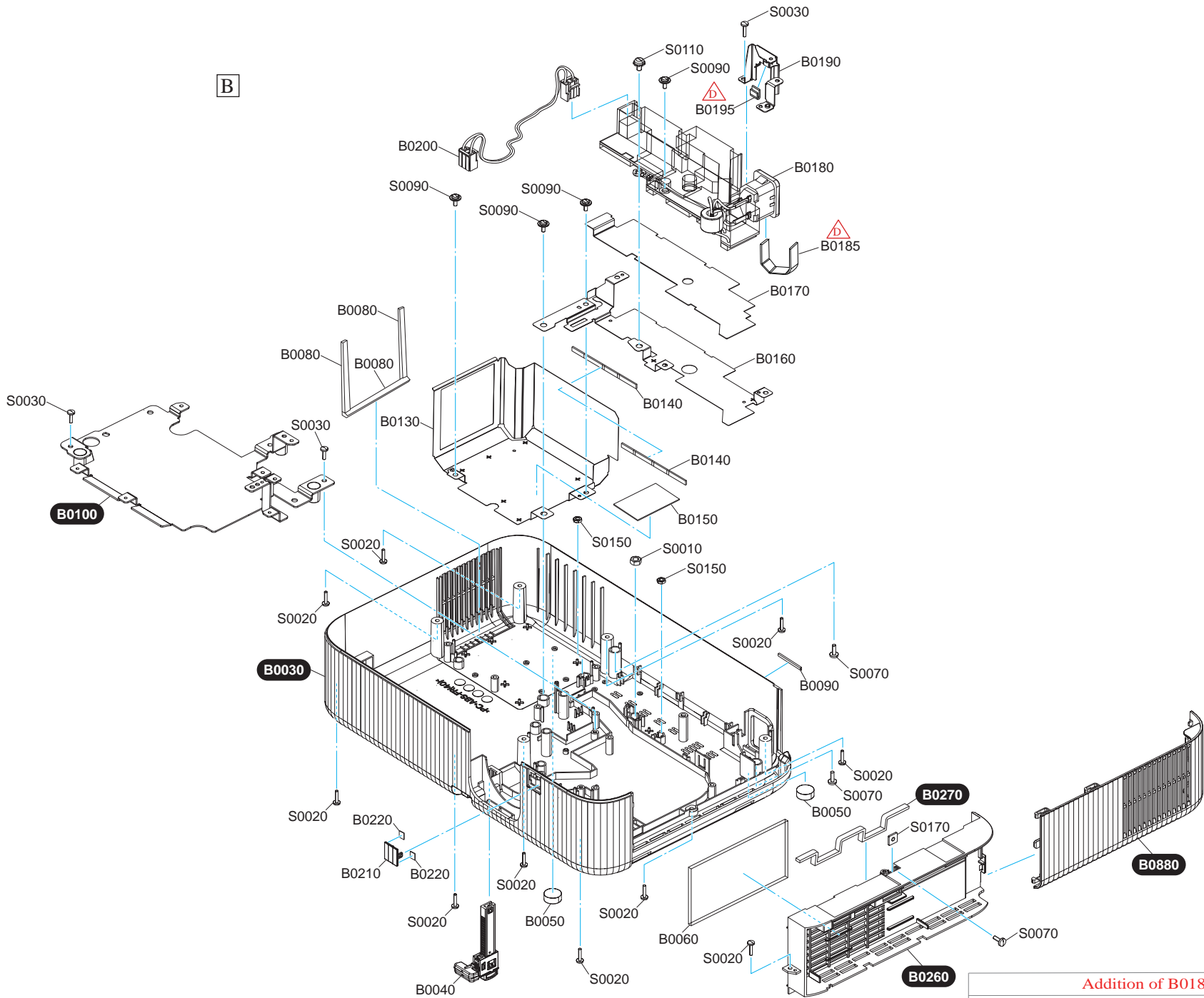

Notes:
 White/Black reversed parts code (written by white text on black circle)
 This parts are different by model and defined multiple parts code (please check SPI for actual parts code)
 By case , some model have no parts though the parts is shown on this diagram.

	Addition of B0185,B0195	D
	Deletion of B2990	C
	Addition of B0255	B
	First Release	A
	History	Rev.No.
Model Name	CO-FH01/CO-FH02/CO-W01	